

Multidimensional Resilience Decision-Making On A Multistage High-Speed Axial Compressor

Julian Salomon

Institute for Risk and Reliability, Leibniz Universität Hannover, Germany.

E-mail: salomon@irz.uni-hannover.de

Jasper Behrendorf

Institute for Risk and Reliability, Leibniz Universität Hannover, Germany.

E-mail: behrendorf@irz.uni-hannover.de

Matteo Broggi

Institute for Risk and Reliability, Leibniz Universität Hannover, Germany.

E-mail: broggi@irz.uni-hannover.de

Stefan Weber

Institute of Probability and Statistics, Leibniz Universität Hannover, Germany.

E-mail: sweber@stochastik.uni-hannover.de

Michael Beer

Institute for Risk and Reliability, Leibniz Universität Hannover, Germany.

Institute for Risk and Uncertainty, University of Liverpool, UK.

International Joint Research Center for Engineering Reliability and Stochastic Mechanics (ERSM), Tongji University, China.

E-mail: beer@irz.uni-hannover.de

The resilience of complex systems such as gas turbines, industrial plants, or critical infrastructure networks is of increasingly higher interest to engineers. Instead of solely concentrating on the robustness of systems and their ability to withstand certain threats, research is more and more focused on their ability to recover from these events as well. Appropriate quantitative measures of resilience can support decision-makers seeking to improve or to design complex systems. In this paper, a previously developed comprehensive and adaptable resilience-based decision-making method is extended to handle higher-dimensional problems subject to monetary constraints. The technique applies a grid search algorithm for systemic risk measures to significantly reduce the computational effort. In order to demonstrate its usefulness, the extended decision-making procedure is applied to a functional model of a multistage high-speed axial compressor.

Keywords: resilience, decision-making, complex systems, multidimensionality

1. Introduction

Gas turbines are complex systems highly utilized in various areas of modern societies, such as propulsion and power generation industries. According to Back et al. (2010), reducing life cycle costs and meeting increasingly stringent regulations on greenhouse gas emissions are the key challenges faced by gas turbine operators. Therefore, for environmental and economic reasons, it is of utmost importance to optimize the performance of these capital goods over their lifetime. It is evident that these systems are exposed to a multitude of adverse influences of natural, techni-

cal and anthropogenic origin. These influences affect the functionality of gas turbines, e.g. by leading to blade roughening, a major cause of performance deterioration (Back et al., 2010). In particular, fouling of the axial compressor has a decisive influence on the performance as the compressor forms a fundamental component of a gas turbine or a jet engine (Tarabrin et al., 1998). According to Bons (2010) the degradation of axial compressors is caused by a variety of operating and environmental factors. The main contributors include ingested aerosols such as salt spray from marine applications, airborne dust, sand, pollen,

Proceedings of the 29th European Safety and Reliability Conference.

Edited by Michael Beer and Enrico Zio

Copyright © 2019 European Safety and Reliability Association.

Published by Research Publishing, Singapore.

ISBN: 978-981-11-2724-3; doi:10.3850/978-981-11-2724-3_0992-cd

combustion particles and volcanic ash, as well as occasionally larger objects such as accumulations of ice. These foreign particles interact with and deposit on the components, especially the blades, resulting in an increased surface roughness.

Given the high and increasing complexity of technical systems such as the axial compressors, identification and prevention of all potential adverse impacts is infeasible. It is therefore important, that novel developments in technical engineering focus not only on monitoring and improving the robustness and reliability of systems but also on their recovery from adverse events (Tran et al., 2017). The concept of resilience encompasses these developments: analyzing and optimizing robustness, reliability and recovery of systems – both from a technical and from an economic perspective (Cimellaro et al., 2010; Ayyub, 2015; Fang et al., 2015). Resilience applied to the artificial systems of our modern society leads to a paradigm shift. Secure systems cannot only be based on strategies that prevent failures but must include strategies for the efficient recovery in cases of failure.

In engineering, the concept of resilience has steadily grown in popularity in recent years (Bergström et al., 2015; Patriarca et al., 2018). The term “resilience” occurs in various areas such as ecology, economics, psychology as well as in the context of mechanical systems and is derived from the Latin word “resilire”, meaning “to bounce back”. The concept of resilience first appeared in the domain of ecological systems by Holling (1973). Although numerous other definitions from various scientists followed (Fiksel, 2003; Little, 2003; Hollnagel et al., 2006; Bruneau and Reinhorn, 2007; Youn et al., 2011), most of them have certain key aspects in common which are captured by Holling’s early definition (Holling, 1973).

Ayyub (2014) provides a literature review and develops a comprehensive definition of resilience in the context of complex systems based on the content of the Presidential Policy Directive (PPD) on critical infrastructure security and resilience (Presidential Policy Directive (PPD), 2013). His novel definition incorporates the former definitions, and provides a solid foundation for the quantification of resilience.

There are numerous options for increasing resilience of complex multi-component systems such as multistage axial compressors. In addition, resources are not unlimited and resilience cannot be arbitrarily increased. Therefore, it is indispensable for realistic methods not only to distinguish and balance between a large number of different resilience-enhancing controls, but to include monetary aspects as well (Gilbert and Ayyub, 2016; Fang and Sansavini, 2017).

Salomon et al. (2019) provide a method to identify the most cost-efficient allocation of resilient-

enhancing investments by combining the resilience metric of Ouyang et al. (2012) and the systemic risk measure by Feinstein et al. (2017). Their approach allows for a direct comparison of the impact of heterogeneous controls on the resilience of a system over any period of time in a two dimensional parameter space. In this paper the previously introduced resilience decision-making method is extended to problems with higher dimensional parameter spaces and applied to a functional model of an axial compressor for a differentiated resilience analysis.

The paper is structured as follows: Section 2 briefly describes the fundamentals of the resilience decision-making method and the challenging task of its extension to n -dimensional applications. In Section 3 the extended method is applied to a functional model of an multistage axial compressor. The paper concludes with a summary of the results and discusses questions for future research.

2. Resilience Decision-Making: Fundamentals

This section recaps the the resilience decision-making procedure proposed by Salomon et al. (2019). The method is based on the fusion of three key elements: A suitable metric for resilience quantification of complex systems, an adaptation of a systemic risk measure and the utilization of a grid search algorithm to increase computational efficiency.

2.1. Resilience Quantification

The availability of quantitative resilience measures is a basic prerequisite for the application of resilience to engineering problems. Hosseini et al. (2016) provide a survey of resilience metrics that have appeared during the last two decades as well as a categorization to subdivide them. The time-dependent probabilistic resilience metrics form one category and may be regarded as particularly comprehensive. According to Hosseini et al. (2016) and Henry and Ramirez-Marquez (2012) these, mostly performance-based, metrics are capable of taking into account the following system and transition states after a disturbance event: (i) The original stable state whose duration can be interpreted as the reliability of the system. (ii) The vulnerability of the system, represented by a loss of performance after the occurrence of a disruptive event; the robustness of the system mitigates the loss of performance. (iii) The recoverability of the system, characterized by the disrupted state of the system and its recovery to a new stable state. An illustration of these three phases is shown in Fig. 1.

In their approach, Salomon et al. (2019) adopt the time-dependent probabilistic metric developed

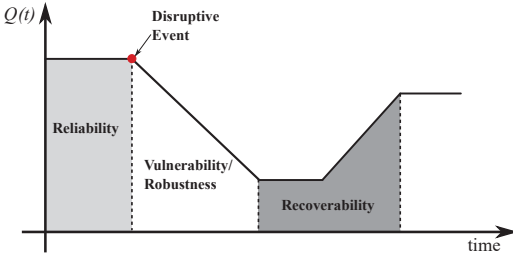

Fig. 1. In the evolution of a system after the impact of a disruptive event, different phases can be distinguished: (i) the original stable state, (ii) disruptive impact, vulnerability, (iii) disrupted state and recovery; adapted from Henry and Ramirez-Marquez (2012).

by Ouyang et al. (2012). It is defined as the expected ratio of the integral over the actual system performance $Q(t)$ and the integral of a target system performance $\mathcal{T}Q(t)$:

$$Res = E[Y], \tag{1}$$

where

$$Y = \frac{\int_0^T Q(t)dt}{\int_0^T \mathcal{T}Q(t)dt}. \tag{2}$$

The system performance $Q(t)$ and the target system performance $\mathcal{T}Q(t)$ are stochastic processes. $\mathcal{T}Q(t)$ may also be assumed as a non-random constant $\mathcal{T}Q$ for the sake of simplicity. The resilience metric takes values between 0 and 1. A value of $Res = 1$ indicates a system performance corresponding to the target performance, while $Res = 0$ indicates that the system is not working during the considered time period.

2.2. Adapted Systemic Risk Measure

In Feinstein et al. (2017) the authors propose a novel approach to measuring risk inherent in complex systems. The methodology is based on two key components: A suitable descriptive input-output model and, an acceptance criterion representing the normative safety standards of a regulatory authority. These systemic risk measures were e.g. considered in finance (Weber and Weske, 2017). In Salomon et al. (2019) this methodology is adapted for the application to engineering systems as follows.

Consider a technical system with l components $i \in \{1, \dots, l\}$ of $j_i \in \{1, 2, \dots, b\} \subseteq \mathbb{N}$ types with n properties influencing the system performance $Q(t)$, in the following called “endowment properties”. A component i can then be characterized by a row vector

$$(a_i; j_i) = (\eta_{i1}, \eta_{i2}, \dots, \eta_{in}; j_i) \in \mathbb{R}^{(1 \times n)} \times \mathbb{N}, \tag{3}$$

where $(\eta_{i1}, \eta_{i2}, \dots, \eta_{in})$ are the numerical values of the n relevant endowment properties. The system is completely described by a pair, consisting of the matrix $A \in \mathbb{R}^{(l \times n)}$ and the column vector $z \in \mathbb{N}^l$ that captures the components’ types:

$$(A; z) = \begin{pmatrix} \eta_{11} & \eta_{12} & \dots & \eta_{1n}; & z_1 \\ \eta_{21} & \eta_{22} & \dots & \eta_{2n}; & z_2 \\ \vdots & \vdots & & \vdots & \vdots \\ \eta_{l1} & \eta_{l2} & \dots & \eta_{ln}; & z_l \end{pmatrix}. \tag{4}$$

The descriptive input-output model $Y = Y_{(A;z)}$ is defined by these pairs. Consider the following example of a specific acceptance set

$$A = \{X \in \mathcal{X} \mid E[X] \geq \alpha\} \tag{5}$$

with $\alpha \in [0, 1]$. A corresponding risk measure is defined by

$$R(Y) = \{A \in \mathbb{R}^{l \times n} \mid Y_{(A;z)} \in \mathcal{A}\}, \tag{6}$$

as the set of all allocations of the system endowment properties A such that the altered system possesses a resilience greater or equal to α .

2.3. Grid Search Algorithm and the Curse of Dimensionality

According to Feinstein et al. (2017), systemic risk measures can be determined by a combination of a grid search algorithm and stochastic simulation. In this study, Monte Carlo simulation is used to estimate the probabilistic resilience metric (Eq. 1, Eq. 2) for different system configurations. A significant advantage of the grid search algorithm is the substantial reduction in computing time, as only a fraction of all possible system configurations has to be evaluated. The algorithm consists of two phases:

- (I) Search along the main diagonal of the parameter space until the first acceptable combination of endowment properties (based on the adapted risk measure) is found.
- (II) Determine the Pareto frontier between the acceptance set $R(Y)$ and its complement $R(Y)^c$.

The algorithm is able to compute the entirety of $R(Y)$ while significantly reducing the computational effort due to the monotonic nature of the input-output model $Y_{(A;z)}$. For a detailed description of a grid search algorithm for two dimensional problems, see Feinstein et al. (2017), Ch. 4.

In Salomon et al. (2019) this algorithm was included in the resilience decision-making method and applied to case studies with two dimensional parameter spaces. In their work, Feinstein et al. (2017) point out that the grid search algorithm is

applicable to higher dimensional problems, however “[...] at the price of substantially larger computation times and required memory capacity.” When analyzing technical real world systems, it is often imperative to consider a large number of influencing factors and thus a higher dimensionality of the parameter space. Therefore, in the following section, an extension of the previously proposed resilience decision-making methodology to n -dimensional problems is applied to the four-dimensional model of an axial compressor.

3. Resilience Decision-Making: Multistage High-Speed Axial Compressor

Axial compressors are complex, multi-component key elements of gas turbines. Therefore, in both design and maintenance, it is critical to consider as many system performance influencing factors as possible to maximize the compressor’s resilience efficiently. In order to illustrate this, the resilience decision-making analysis of an axial compressor model, carried out in Salomon et al. (2019), is extended to deal with components of different types.

3.1. Model

In a previous work within the Collaborative Research Center 871, funded by the German Research Foundation Miro et al. (2018) provide a functional model of the four-stage high-speed axial compressor of the Institute for Turbomachinery and Fluid Dynamics at Leibniz Universität Hannover, representing its reliability characteristic and functionality. For detailed information about this axial compressor see: Braun and Seume (2006); Hellmich and Seume (2008); Siemann et al. (2016).

The model captures the dependence of the overall compressor performance, namely the total-to-total pressure ratio and the total-to-total isentropic efficiency, on the surface roughness of the individual blades, arranged in rotor and stator rows. It is based on the results of a sensitivity analysis of the aerodynamic model of the compressor and calculated Relative Important Indices, cf. (Feng et al., 2016). A network representation of the functional model is shown in Fig. 2. Each component represents either a stator (S1 - S4) or rotor row (R1 - R4).

The rows are classified into four component types $j_i \in \{1, 2, 3, 4\} \forall i \in \{1, \dots, 8\}$. This classification as well as the components’ arrangement is chosen based on the resulting effect of their blade roughness on the two performance parameters of the axial compressor. More specific, an interruption between start and end means exceeding a performance variation of at least 25%, corresponding to a non-functional compressor. This

defines the system performance $Q(t)$ of the functional model for the subsequent application of the resilience decision-making method. The system performance is determined at each time point t_h and is 1 if a path exists from start to end or 0 if this connection is interrupted. More detailed information on the functional model and its formulation can be obtained from Miro et al. (2018).

For the analysis, each row, i.e. each component of the functional model, is assumed to be characterized by two endowment properties, a roughness resistance re and a recovery improvement r^* , so that a component is fully described by $(a_i; j_i) = (re_i, r_i^*; j_i)$. In this context, roughness resistance can be interpreted as a coating that counteracts roughening of the blade surface. Both, the roughness resistance re_i and the recovery improvement r_i^* of each row i are assumed to be functions of the type j_i , i.e. $re_i = re_{j_i}, r_i^* = r_{j_i}^*$ if $j_i = j_{j_i}$.

Each component of the functional model can fail at random after the system performance has been computed at time t_h . A failed component is treated as no longer present in the model and does not contribute to the overall system performance at time t_{h+1} and all subsequent time points until it is fully recovered. The failure probability of a component i in the time interval (t_h, t_{h+1}) is assumed to be constant in time, cf. Miro et al. (2018), and is given by

$$P \{(a_i; j_i) \text{ fails during } (t_h, t_{h+1})\} = \Delta t \cdot \lambda_i \quad (7)$$

with

$$\lambda_i = 0.8 - 0.03 \cdot re_i, \quad (8)$$

where λ_i is the time-independent failure rate. An increase of the roughness resistance of a row of blades reduces the degradation of the surface and thus the corresponding failure rate λ_i .

If a component i failed, its functionality is assumed to be fully recovered after a number of time steps according to

$$r = r_{max} - r^* \quad \text{with} \quad r^* < r_{max} \quad (9)$$

where r_{max} is an upper bound for number of time steps for recovery and r^* is a reduction specific to the component.

3.2. Costs of Endowment Properties

The optimal endowment properties are related to the quality of the components, and an increase in their production quality is associated with large costs. This should be taken in to account in the decision-making process. As discussed in Mettas (2000), an increase of the reliability of components in complex networks might be associated with an exponential increase in their costs.

An increase of the endowment property “roughness resistance” decreases the failure rate of the blades of a row and therefore improves reliability

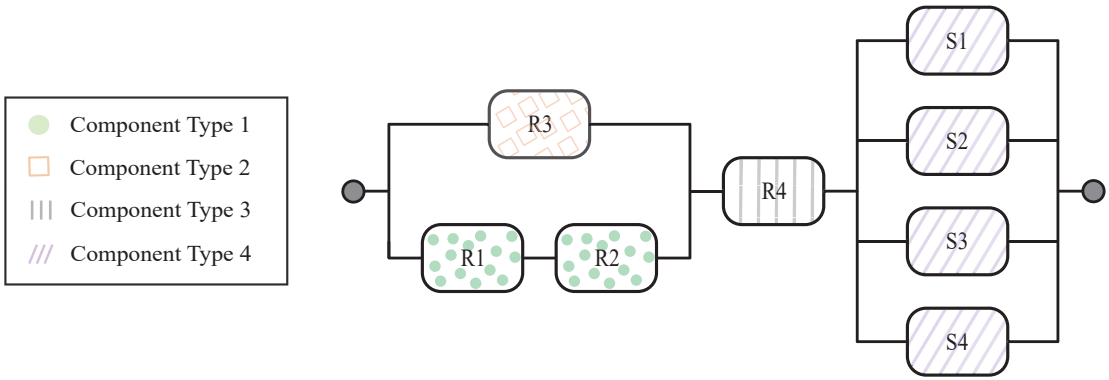

Fig. 2. Functional model of the multistage high-speed axial compressor

(see Eq. 7 and Eq. 8). Thus, its total cost is defined by

$$cost^{re} = \sum_{i=1}^8 price_{(re_i;j_i)}^{re} \cdot 1.2^{(re_i-1)}, \quad (10)$$

where re_i is the “roughness resistance” value of component i , j_i its type and $price_{(re_i;j_i)}^{re}$ a common basic price. In a similar way an exponential relationship is assumed for the cost associated with recovery improvement:

$$cost^* = \sum_{i=1}^8 price_{(r^*;j_i)}^* \cdot 1.2^{(r_i^*-1)}. \quad (11)$$

The total cost $cost_{(A;z)}$ of an endowment is the sum of these costs:

$$cost_{(A;z)} = cost^{re} + cost^*. \quad (12)$$

3.3. Scenario

In order to apply the four dimensional decision-making method for resilience-enhancing endowments to the multistage high-speed axial compressor, the model parameter and simulation parameter values, shown in Tab. 1, are considered. In a first step, the set of all acceptable endowments corresponding to a resilience value of at least $Res = 0.85$ over the considered time period is determined. Since any improvement of the axial compressor blades is associated with costs, the next step is to find the cheapest acceptable endowment denoted by \hat{A} . The recovery improvement r^* is assumed to be fixed for all components, regardless of the type, $r_i^* = 11 \forall i \in \{1, \dots, l\}$ and the roughness resistance re is explored over $re_i \in \{1, \dots, 20\} \forall i \in \{1, \dots, l\}$. The roughness resistance values can be interpreted as increasing quality levels of coatings.

Figure 3 illustrates the results of the grid search algorithm. It shows the roughness resistance combinations contained in $R(Y)$, i.e. all combinations

Table 1. Parameter values for the resilience decision-making method for the functional model of the multistage high-speed axial compressor.

Parameter	Scenario
Number of blade rows l	8
Acceptance threshold α	0.85
Number of time steps u	200
Length of a time step Δt	0.05
Failure rate λ	0.8
Maximum recovery time r_{max}	21
Recovery improvement r^*	11
Roughness resistance re	$re_i \in \{1, \dots, 20\}$
Recovery improvement price: $price_{(r^*;j_i)}^*$	600€
Roughness resistance price: $price_{(re_i;j_i)}^{re}$	800€ $\forall j_i \in \{1, 2, 3\}$ 500€ $\forall j_i = 4$

that lead to a satisfactory system resilience of at least $Res = 0.85$. It can clearly be seen that the roughness resistance of the blades of stage four (component type 3) has the highest impact on the system resilience. Combinations with coating quality levels of $re_i \leq 15$ in the fourth stage are insufficient to achieve an acceptable degree of resilience, regardless of the endowment property values of the other component types. In addition, the roughness resistance of the four stators (component type 4) has the least influence on the system resilience out of all types. Endowments with a minimum coating quality level of $(re_i, 4) = 1$ are sufficient to achieve acceptable resilience values. The same applies to the rotors of component type 1 and type 2. Although, in comparison to the stators, components of the other types need significantly higher coating quality levels in order to compensate small roughness resistance values.

The design, maintenance and optimization of technical capital goods, such as an axial compressor, is invariably restricted by monetary con-

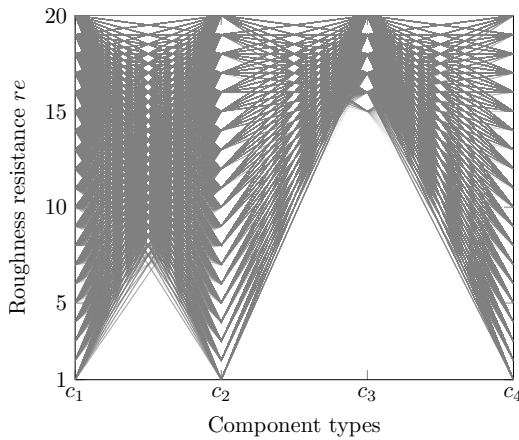

Fig. 3. Numerical results of the 4D grid search algorithm for the functional model of the axial compressor with explored roughness resistance values

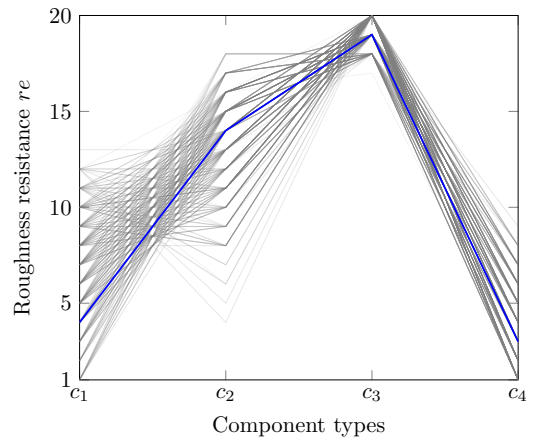

Fig. 4. Numerical results of the 4D grid search algorithm for the functional model of the axial compressor with explored roughness resistance values and a cost threshold for roughness resistance of 50 000€

straints. For decision-making, it is crucial to be able to take these monetary constraints into account. Therefore, Fig. 4 exclusively shows the roughness resistance combinations contained in $R(Y)$ that lead to a satisfying system resilience of $Res = 0.85$ and, are less expensive than a predefined cost limit for roughness resistance, which is arbitrarily assumed to be $cost^{re} = 50\,000\text{€}$ in this case study.

The results indicate that only configurations with low coating quality levels for stators (component type 4) are below the cost limit. Firstly, this is due to the already mentioned low influence on system resilience, and secondly, to the high costs of the quality levels for the stators. Although the basic price of 500€ is quite low, in terms of the costs for the entire component type it is significantly higher than for the other types due to the higher number of components of this type. In addition, only configurations that provide the highest quality levels of $(re_i, 3) \geq 17$ for the rotor of type 3 are acceptable and below the price limit. The roughness resistance of this rotor has such a significant influence on the system resilience that at lower quality levels, the compensation by higher quality levels of the remaining stages would be above the given budget. Although the roughness resistance of the rotor of component type 2 has less of an influence on system resilience than that of component type 3, minimal quality levels of the coating cannot be compensated by high qualities of the other components. Thus, at least $(re_i, 2) = 4$ is required to fulfill the acceptance criterion.

The grid search algorithm is able to reduce the numerical effort for the computation of $R(Y)$ by about 98%. As such, only 2% of the feasible combinations of roughness resistance values have to

be evaluated.

Taking into account the base prices in Tab. 1, the cheapest endowment is characterized by roughness resistances of $(re_i, 1) = 4$, $(re_i, 2) = 14$, $(re_i, 3) = 19$, $(re_i, 4) = 3$ for the respective components. In Fig. 4 the corresponding configuration is highlighted in blue. The final cost results from Eq. 12 as $cost_{(A;z)} = cost^{re} + cost^* = 42\,604\text{€} + 35\,664\text{€} = 78\,268\text{€}$.

Note, that although the method is applied to a 4-dimensional problem, its application to higher-dimensional problems is only limited by memory and computational time constraints.

4. CONCLUSION

This paper addresses the challenge of decision-making in technical systems with multidimensional resilience-influencing parameter spaces, by adapting the resilience decision-making methodology presented in Salomon et al. (2019) to higher dimensional problems. This extended approach allows a more comprehensive direct comparison of the impact of heterogeneous controls on the resilience of a system. More precisely, this is obtained by extending the utilized grid search algorithm.

The extended method is applied on a functional model of an axial compressor with resilience influencing stages of four different component types. The results obtained with this extended method are consistent with the data on influence of the individual component types on the isentropic efficiency of the compressor used to construct the functional model (Miro et al., 2018). Note, that this extended approach is applicable to systems of any kind.

Monetary restrictions are included in the anal-

ysis as well. More precisely, not only the most cost-effective, accepted endowment is identified, but subsets of the set of all accepted endowments below defined price levels can be formed. Budget limits can thus be specifically taken into account in the decision-making process.

Future work regarding multidimensional parameter spaces must deal with the limitations in computing time and storage capacity in order to enable application to even higher-dimensional problems. Namely, techniques such as advanced sampling methods, e.g. Subset Simulation must be investigated to further reduce numerical effort. At the same time, efficient storage solutions, for instance sparse matrices have to be explored as storing the full resilience information on a high-dimensional system can quickly reach memory limits. Alternatively, the grid search algorithm included in the resilience decision-making could either be optimized or exchanged for an entirely different optimization method depending on the problem at hand.

Acknowledgment

The authors kindly thank the German Research Foundation (DFG) for the financial support to accomplish the research project D5 “Resilience Based Decision Criteria for Optimal Regeneration” within the Collaborative Research Center (CRC) 871 - Regeneration of Complex Capital Goods.

References

- Ayyub, B. M. (2014). Systems resilience for multihazard environments: Definition, metrics, and valuation for decision making. *Risk Analysis* 34(2), 340–355.
- Ayyub, B. M. (2015). Practical resilience metrics for planning, design, and decision making. *ASCE-ASME Journal of Risk and Uncertainty in Engineering Systems, Part A: Civil Engineering* 1(3), 04015008.
- Back, S. C., J. H. Sohn, and S. J. Song (2010). Impact of Surface Roughness on Compressor Cascade Performance. *Journal of Fluids Engineering* 132(6), 1–6.
- Bergström, J., R. Van Winsen, and E. Henriqson (2015). On the rationale of resilience in the domain of safety: A literature review. *Reliability Engineering and System Safety* 141, 131–141.
- Bons, J. P. (2010). A review of surface roughness effects in gas turbines. *Journal of turbomachinery* 132(2), 021004.
- Braun, M. and J. Seume (2006). Forward Sweep in a Four-Stage High-Speed Axial Compressor. *ASME Turbo Expo 2006: Power for Land, Sea, and Air Volume 6: Turbomachinery, Parts A and B*, 141 – 152.
- Bruneau, M. and A. Reinhorn (2007). Exploring the concept of seismic resilience for acute care facilities. *Earthquake Spectra* 23(1), 41–62.
- Cimellaro, G. P., A. M. Reinhorn, and M. Bruneau (2010). Framework for analytical quantification of disaster resilience. *Engineering Structures* 32(11), 3639–3649.
- Fang, Y., N. Pedroni, and E. Zio (2015). Optimization of Cascade-Resilient Electrical Infrastructures and its Validation by Power Flow Modeling. *Risk Analysis* 35(4), 594–607.
- Fang, Y. and G. Sansavini (2017). Optimizing power system investments and resilience against attacks. *Reliability Engineering and System Safety* 159, 161–173.
- Feinstein, Z., B. Rudloff, and S. Weber (2017). Measures of Systemic Risk. *SIAM Journal on Financial Mathematics* 8(1), 672–708.
- Feng, G., E. Patelli, M. Beer, and F. P. Coolen (2016). Imprecise system reliability and component importance based on survival signature. *Reliability Engineering & System Safety* 150, 116–125.
- Fiksel, J. (2003). Designing Resilient, Sustainable Systems. *Environmental Science and Technology* 37(23), 5330–5339.
- Gilbert, S. and B. M. Ayyub (2016). Models for the Economics of Resilience. *ASCE-ASME Journal of Risk and Uncertainty in Engineering Systems, Part A: Civil Engineering* 2.
- Hellmich, B. and J. Seume (2008). Causes of Acoustic Resonance in a High-Speed Axial Compressor. *ASME. J. Turbomach.* 130(3), 031003–031003–9.
- Henry, D. and J. E. Ramirez-Marquez (2012). Generic metrics and quantitative approaches for system resilience as a function of time. *Reliability Engineering and System Safety* 99, 114–122.
- Holling, C. S. (1973). Resilience and Stability of Ecological Systems. *Annu.Rev.Ecol.Syst.* 4, 1–23.
- Hollnagel, E., D. E. Woods, and N. Levensen (2006). *Resilience Engineering: Concepts and Precepts*. Aldershot, UK: Ashgate Publishing.
- Hosseini, S., K. Barker, and J. E. Ramirez-Marquez (2016, jan). A review of definitions and measures of system resilience. *Reliability Engineering & System Safety* 145, 47–61.
- Little, R. G. (2003). Toward more robust infrastructure: Observations on improving the resilience and reliability of critical systems. *Proceedings of the 36th Annual Hawaii International Conference on System Sciences, HICSS 2003*.
- Mettas, A. (2000). Reliability allocation and optimization for complex systems. *Reliability and Maintainability Symposium, 2000. Proceedings. Annual*, 216–221.
- Miro, S., T. Willeke, M. Broggi, J. Seume, and M. Beer (2018). Reliability Analysis of an Axial Compressor Based on One-Dimensional

- Flow Modeling and Survival Signature. *ASCE-ASME Journal of Risk and Uncertainty in Engineering Systems, Part B: Mechanical Engineering*.
- Ouyang, M., L. Dueñas-Osorio, and X. Min (2012, may). A three-stage resilience analysis framework for urban infrastructure systems. *Structural Safety* 36-37, 23–31.
- Patriarca, R., J. Bergström, G. Di Gravio, and F. Costantino (2018). Resilience engineering: Current status of the research and future challenges. *Safety Science* 102, 79–100.
- Presidential Policy Directive (PPD) (2013). Critical infrastructure security and resilience. (accessed Nov. 9, 2018).
- Salomon, J., M. Broggi, S. Kruse, S. Weber, and M. Beer (2019). Resilience Decision-Making For Complex Systems. *ASCE-ASME Journal of Risk and Uncertainty in Engineering Systems, Part B: Mechanical Engineering*. (under revision).
- Siemann, J., I. Krenz, and J. Seume (2016). Experimental Investigation of Aspiration in a Multi-Stage High-Speed Axial-Compressor. *ASME Turbo Expo: Power for Land, Sea, and Air Volume 2A: Turbomachinery*.
- Tarabrin, A., V. Schurovsky, A. Bodrov, and J.-P. Stalder (1998). Influence of axial compressor fouling on gas turbine unit performance based on different schemes and with different initial parameters. In *ASME 1998 International Gas Turbine and Aeroengine Congress and Exhibition*, pp. V004T11A006–V004T11A006. American Society of Mechanical Engineers.
- Tran, H. T., M. Balchanos, J. C. Domercant, and D. N. Mavris (2017). A framework for the quantitative assessment of performance-based system resilience. *Reliability Engineering & System Safety* 158, 73–84.
- Weber, S. and K. Weske (2017). The joint impact of bankruptcy costs, fire sales and cross-holdings on systemic risk in financial networks. *Probability, Uncertainty and Quantitative Risk* 2(1).
- Youn, B. D., C. Hu, and P. Wang (2011). Resilience-Driven System Design of Complex Engineered Systems. *Journal of Mechanical Design* 133(10), 101011.